



Job _____ Item No. _____

Notes: _____

Bench Model Reversible Sheeter

Model Number: LSA516 LSA520

Reversible Sheeter

SPECIFICATIONS



Shown in Optional S/S Construction

DESCRIPTION

The LSA516 & LSA520 are ideal for production areas that handle doughs from cookie to croissant. Simple to operate, easy to clean, and folds to store freeing up more workspace. Our bench model sheeter is designed for consistency and labor cost savings.

SHORT FORM SPECIFICATIONS

Reversible Sheeter, Bench Style, Electric, Adjustable Belt Thickness from 1/32" to 1 1/2", 20 Adjustable Speed Settings, 22 LB Dough Capacity, Polyurethane Belts, Folds for Storage, Thermal overload protection for motor, Stainless Steel Rollers, Flour Reservoir Above Rollers, 63" Wide Conveyor on LSA516 & 78 3/4" on LSA520, Wire guard for Rollers Featuring Motor Cutoff Switch, Catch Pan on Each End of Belt, 3/4 HP Motor, One year labor and two year parts warranty

WARRANTY

The LSA516 & LSA520 both come with a one year warranty for parts and two year warranty for labor.

FEATURES

- Folds Up for Easy Storage
- 20 Adjustable Speeds
- Flour Reservoir Above Rollers
- Stainless Steel Catch Pans on End of Each Belt
- Synchronized Belt System
- Adjustable Thickness from 1/32" to 1 1/2"
- Dual Hand Controls for Forward and Reverse on Each Side
- Emergency Stop
- Easy to Remove and Adjust Scrapers
- Stainless Steel Rollers
- Polyurethane Belts
- Protective Guards with Motor Shutoff Feature

OPTIONS AND ACCESSORIES

- Heavy Duty Stand with Casters (LSB516T)
- Stainless Steel Construction (Suffix I)

CERTIFICATIONS

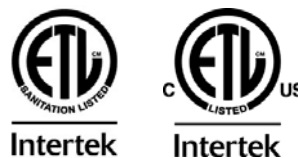

Doyon/NU-VU

5600 13th Street, Menominee, MI 49858

Phone 800.338.9886 • Fax 906.863.5889

www.doyon.qc.ca

Follow Us





SPECIFICATIONS

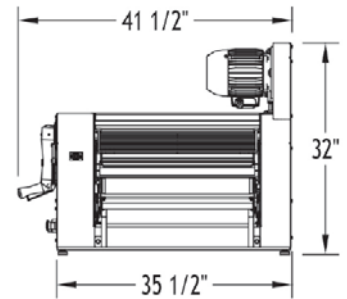
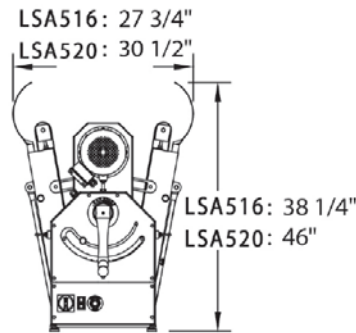
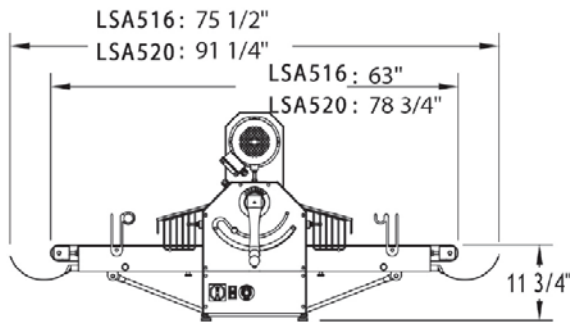

CLEARANCES

A clearance of at least 6" (152mm) must be maintained around sides. Do not place anything directly underneath the belts.

ELECTRICAL DATA

Single electrical connection, 120V, 993 watts, 8.3A, 60Hz, single phase, NEMA 5-15P plug.

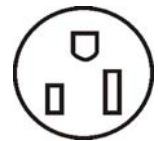

Model	Conveyor Dimensions				Motor (HP)	Height [A]		Depth [B]		Width [C]		Weight	
	D		W			in	mm	in	mm	in	mm	lbs	kg
	In	mm	In	mm									
LSA516	19 11/16	500	63	1600	3/4	32	813	41 1/2	1054	75 1/2	1918	445	201
LSA520	19 11/16	500	78 3/4	2000	3/4	32	813	41 1/2	1054	91 1/4	2318	575	261

Due to periodic changes in designs, methods, procedures, policies and regulations, the specifications contained in this sheet are subject to change without notice. While Doyon/NU-VU exercises good faith efforts to provide information that is accurate, we are not responsible for errors or omissions in information provided or conclusions reached as a result of using these specifications. By using the information provided, the user assumes all risks in connection with such use.

Doyon/NU-VU

5600 13th Street, Menominee, MI 49858

Phone 800.338.9886 • Fax 906.863.5889

www.doyon.qc.ca



Printed in the USA • LSA • Rev. A • 03.2021

Specifications are subject to change without notice and are not intended for installation purposes.